

LABEL SYSTEMS



**BAND STYLE
CONVEYOR SYSTEM**

BAND STYLE CONVEYOR SYSTEM FROM LABEL SYSTEMS

TECHNICAL DATA

- **Label Heads Available**
LS75 / LS400 / LS450 / LS550
- **Label Widths**
80 mm 120 mm 150 mm 200 mm
(3.15") (4.72") (5.9") (7.87")
- **Conveyor**
Dimensions: Length 6'6" Width 12"
with speeds up to 90 feet per minute
- **Dispensing Speeds**
0-165 feet per minute depending on
type of head used
- **Construction Materials**
Anodized Aluminum and Stainless Steel,
Powder Coated Steel
- **Drives**
AC Variable (main conveyor)
- **Sensing**
Photo Electric Product and Label Sensing
Other sensor options available

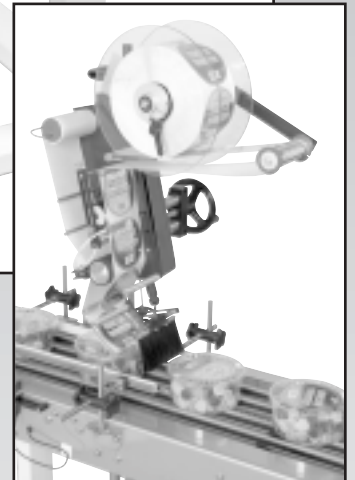
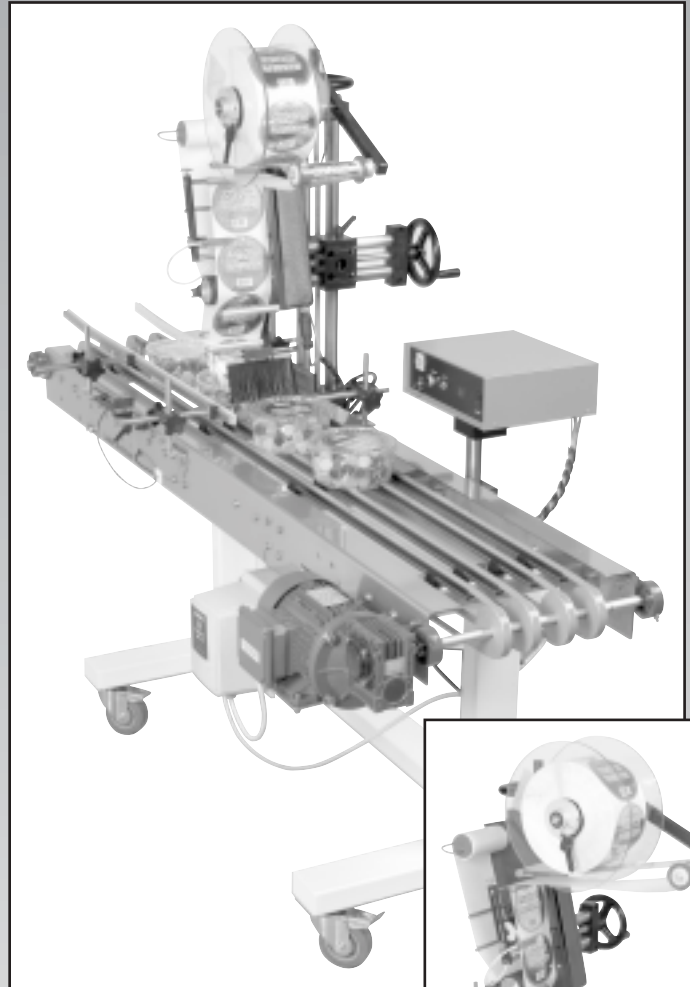

TYPICAL APPLICATIONS

- Top / Bottom Labelling
- 3 Sided ("Nose" Labelling)

CODING AND MARKING

- T.T. Direct
- Hot Stamp Coding
- Laser

OPTIONAL ACCESSORIES

- Missing Label Detectors
- Programmable Counters
- Custom Designed Material
Handling Systems
- Friction Feeders



LABEL SYSTEMS

1334 Kerrisdale Blvd, Unit 2
Newmarket, ON L3Y 3V6
Telephone: (905) 836-7844
Facsimile: (905) 853-9357
Web Site: www.label-systems.com

Distributed by: